

IMPORTANT-READ THIS SECTION FIRST

Before using the RCBS Reloading Dies, read the instruction manual carefully to fully learn how to safely operate the related reloading equipment. Failure to properly operate certain reloading equipment can result in severe personal injury and/or equipment damage. If you have read these instructions and still do not understand some operation, call us at 1-800-533-5000 and a technician will assist you. This instruction manual contains specific safety and operating information. It should be considered a permanent part of your reloading equipment and remain with the equipment at all times for easy reference.

SAFETY

Reloading is an enjoyable and rewarding hobby that can be conducted safely. But, as with any hobby, carelessness or negligence can make reloading hazardous. This product has been designed from the beginning with the user's safety in mind. When reloading, safety rules must be followed. By observing these rules, the chance of a hazardous occurrence causing personal injury or property damage is minimized.

GENERAL

- Use all equipment as the manufacturer recommends. Study the instructions carefully and become thoroughly familiar with the operation of the product. If you do not have written instructions, request a copy from the equipment manufacturer.
- Don't take short cuts. Attempting to bypass established procedures is an invitation to an accident.
- Observe "good housekeeping" in the reloading area. Keep tools and components neat, clean and orderly. Promptly and completely clean up primer and powder spills.
- Reload only when you can give your undivided attention. Do not reload when fatigued or ill, or under the influence of medications or alcohol. Develop a reloading routine to avoid mistakes which may prove hazardous. Don't rush - load at a leisurely pace.
- Always wear adequate eye protection to protect your eyes from flying particles. You assume unnecessary risk when reloading without wearing safety glasses.

LOADING DATA

- Use only laboratory tested reloading data. We highly recommend the current SPEER Reloading Manual.
- **OBSERVE ALL WARNINGS ABOUT THE USE OF MAXIMUM LISTED LOADS.**

PRIMERS AND POWDER

- Store primers and powder beyond the reach of children and away from heat, dampness, open flames and electrical equipment. Avoid areas where static electricity is evident.
- Do not use primers of unknown identity. Scrap unknown primers in accordance with applicable regulations.
- Keep primers in the original factory container until ready to use. Return unused primers to the same factory packaging for safety and to preserve their identity. Primer packaging is designed to provide safe storage.
- **DO NOT** store primers in bulk. The blast of just a few hundred primers is sufficient to cause serious injury to anyone nearby.
- **DO NOT** force primers. Use care in handling primers.
- **DO NOT** have more than one can of powder on the bench at one time. Powder cans should be stored away from the bench to avoid picking up the wrong one.
- **DO NOT** use any powder unless its identity is positively known. The only positive identification is the manufacturer's label on the original canister. Discard all mixed powders and those of uncertain identity.
- If you use a powder measure, replace the lids on both the powder hopper and powder can after the powder hopper has been filled.
- When using a powder measure, settle the powder in the powder hopper before charging any cases. Throw and check the weight of at least ten charges. This will assure you that the correct powder charge is being thrown.
- When you finish a reloading session, pour any remaining powder back into its original factory container. This will preserve the identity and shelf life of the powder.
- **DO NOT** smoke while reloading.

RECORD KEEPING

- Keep complete records of reloads. Apply a descriptive label to each box showing the date produced, and the primer, powder and bullet used. Labels for this purpose are packed with SPEER bullets. **Never attempt to guess at the identity of your ammunition.**

Because RCBS has no control over the choice of components, the way they are assembled, the guns used and the use of this product, we assume no responsibility, expressed or implied, for the use of reloading with this product.

2-DIE SET FOR BOTTLE-NECK RIFLE AND PISTOL CASES

The end of the decapping pin must be at least 3/16" below the end of the die. The expander ball and decapping pin are adjusted by loosening the small lock nut at the top of the die and turning the expander-decapping rod until the desired setting is obtained. When the expander ball is adjusted correctly, the decapping pin will protrude below the bottom of the die just enough to knock out the spent primer. The case is sized (full length or neck), decapped and expanded in one operation. Trim cases after the sizing and expanding operation. We suggest

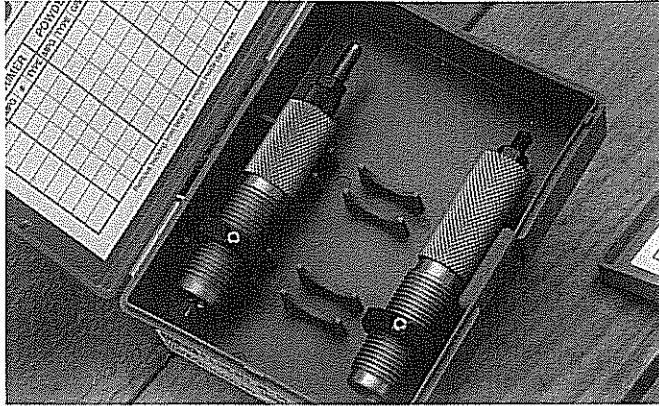

trimming 10 thousandths less than the maximum length. The next step is to prime the case and fill it with the predetermined powder charge. Then seat the bullet. Usually the reloader performs one operation at a time on each lot of cases; sizing and decapping, priming and filling them with powder and then seating the bullets. If cast lead bullets are being used, you will need an RCBS Neck Expander Die. This die expands a sized rifle case neck to the correct diameter and slightly flares (bells) the case mouth for easy bullet seating.

FULL LENGTH OR NECK SIZING

Screw the (full length or neck) sizer die into the press until the die touches the shell holder when the shell holder is brought up to the top of the press stroke. Be sure all the play is removed from the press leverage system. To do this, adjust the die as above, lower the shell holder and set the die 1/8 to 1/4 turn further down so that the press cams over center. Set the large lock nut and you're ready to size.

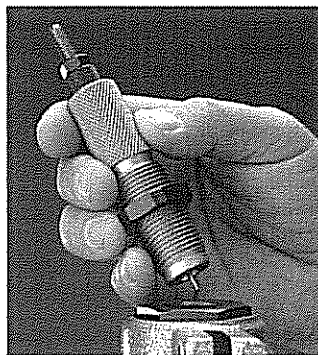

Screw the sizer die into the reloading press.



Notice the sizer die is adjusted so it contacts the shell holder.

BULLET SEATING WITHOUT CRIMPING

IMPORTANT: Please read instructions carefully. Do not adjust the seater die down against the shell holder as it will distort or crush the case. Most rifle and pistol bullets for bottle neck type cases do not have a cannelure or crimping groove and the bullet is therefore seated without crimping. These instructions are for seating the bullet without crimping. To adjust the seater die, place a sized, primed and powder-charged case into the shell holder and run it to the top of the press stroke. Then screw the seater die into the press until you feel it touch the mouth of the case. Back the die up one full turn and set the large lock nut. This will leave a gap



Place a bullet on top of the primed and powder-charged case.

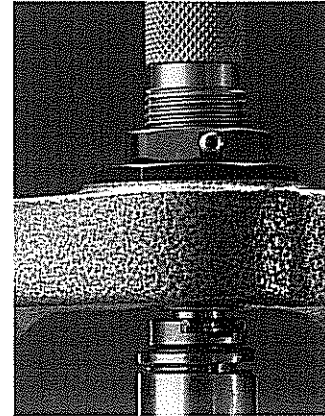

The seater die will seat and, if required, crimp the bullet in one step.

between the bottom of the die and the shell holder. Next, lower the case and insert the bullet in the case mouth. Now slowly run the case into the seater die. Check the bullet for proper seating depth. If the bullet is not seated properly, adjust the seater plug until the proper depth is obtained. Once the proper seating depth is attained, tighten the seater plug lock nut.

BULLET SEATING WITH CRIMPING

IMPORTANT: Please read instructions carefully. Do not adjust the seater die down against the shell holder as it will distort or crush the case. If the bullet you are using has a definite cannelure or crimping groove, the bullet can be seated and crimped, using the following instructions. Before proceeding, cases must be trimmed to the same overall length to assure a consistent crimp. The crimping feature is machined into the seater die body. It is not a special attachment to the seater plug. The die must be moved up or down to obtain the proper crimp adjustment. To adjust the seater die, place a sized, primed and powder-charged case in the shell holder and run it to the top of the press stroke. Screw the seater die into the press until you feel it touch the mouth of the case. Back the die up one full turn and set the large lock nut. This will leave a gap between the bottom of the die and the shell holder. Next, lower the case and insert a bullet in the case mouth. Slowly run the case and bullet into the seater die. Check the bullet for proper seating depth. If the bullet is not seated properly, adjust the seater plug until the proper depth is obtained. Next, adjust the die to crimp. While the uncrimped cartridge is still in the seater die, unscrew the

seater plug several turns. Screw the seater die downward until you feel it touch the mouth of the case. Lower the reloaded cartridge and adjust the seater die downward about 1/8 of a turn. Run the reloaded cartridge back into the seater die and check the crimp. If more crimp is desired, repeat the preceding step by adjusting the die downward 1/8 of a turn at a time. After you are satisfied with the crimp, tighten the large lock nut and run the completed cartridge into the seater die, then lower the seater plug until it touches the bullet. Tighten the seater plug lock nut. Once the seater die is properly adjusted, the bullet is seated and crimped in one operation.

3-DIE SET FOR STRAIGHT-WALL RIFLE AND PISTOL CASES

Reloading straight-wall type cases requires a 3-die set instead of a 2-die set because it is not possible to size and expand the mouth of a straight walled case at the same time. In this 3-die set, the first die sizes and decaps the case. The second die expands and flares (bells) the case mouth to receive the bullet and the third die seats and, if necessary crimps the bullet. If you are reloading one of the following calibers, please read the special notes that follow for important information: .32 S&W Long/.32 H&R Magnum, .357 Magnum/.38 Special, .44 Magnum/.44 Special, .38-40 Winchester, .44-40 Winchester.



SPECIAL NOTES FOR CERTAIN CALIBERS

.32 S&W LONG/.32 H&R MAGNUM

When reloading the .32 S&W Long, follow the regular instructions. Due to the greater overall length of the .32 H&R Magnum case, these dies have to be adjusted above the Shell Holder about 3/16" (except for sizer die). The Expander Assembly furnished is for use with .314" bullets. If other diameter bullets are to be used, contact RCBS.

.357 MAGNUM/.38 SPECIAL & .44 MAGNUM/.44 SPECIAL

These sets are furnished with a spacer ring for use in setting the dies (except the Sizer Die) for the longer magnum cases. Adjust the dies as directed in these instructions. Then use the spacer ring under the large lock nut only when reloading magnum cases. This will give the approximate setting. However additional adjustment may be necessary, depending upon the case length.

SIZING WITH CARBIDE SIZER DIE

Screw the Sizer Die into the press until the die touches the top of the shell holder when the shell holder is brought up to the top of the press stroke. Tighten the large lock nut. DO NOT CAM OVER.

CARBIDE SIZER DIE

A Tungsten Carbide Sizer Die will give you a lifetime of perfect service if properly cared for. However, the die will not withstand severe impact, such as dropping. The shell holder should never strike the bottom of the die. When using a Carbide Sizer Die, it is not necessary to lubricate a pistol straight-wall case. However, the 30M-1 Carbine is heavy-walled, tapered, and must have some lubrication. The .500 S&W and .480 S&W need occasional lubrication as well. We recommend lightly lubricating every fourth or fifth case for best results. Screw the die into the press until it just touches the shell holder. DO NOT CAM OVER.

SIZING WITH STANDARD STEEL SIZER DIES

Screw the Sizer Die into the press until the die touches the top of the shell holder when the shell holder is brought up to the top of the press stroke. Be sure all play is removed from the press leverage system. To do this, adjust the die as above, lower the shell holder and set the die 1/8 to 1/4 of a turn lower. Set the large lock nut. To adjust the expander/decap assembly:

1. Loosen the small lock ring at the top of the die.
2. Adjust the expander/decap assembly so approximately 3/16" of the decap pin is below the end of the die (see cut-away illustration).
3. Tighten the lock ring. To prevent damage to decap pin, check to make sure expander/decap pin assembly is centered in die after tightening. If expander/decap pin assembly is not centered, repeat previous steps 1-3.

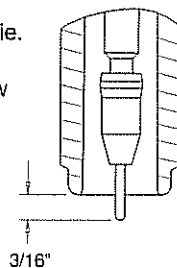

Screw the sizer die into the reloading press.

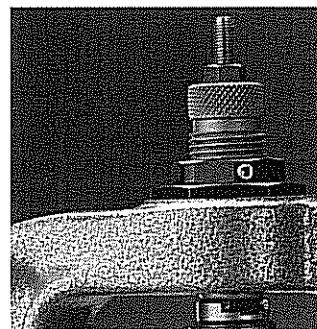

Notice the sizer die is adjusted so it contacts the shell holder.

EXPANDING

Screw the expander die into the press until the die touches the top of the shell holder when the shell holder is brought up to the top of the press stroke. Place a sized case in the shell holder and run it into the expander die. The case mouth should be expanded and flared (belled) just enough to accept the bullet when placed on top of the case. The expander is

tapered and may be adjusted for more or less flaring (belling) by loosening the lock nut on top of the die and turning the expander up or down.

BULLET SEATING WITHOUT CRIMPING

IMPORTANT: Please read instructions carefully. Do not adjust the seater die down against the shell holder, as it will distort or crush the case. Most rifle and pistol bullets for straight-wall type cases have a cannelure or crimping groove and the bullet may be crimped. However, there are a few calibers where the bullet should not be crimped. These instructions are for seating the bullet without crimping. To adjust the seater die, place a sized, primed and powder-charged case into the shell holder and run it to the top of the press stroke. Screw the seater die into the press until you feel it touch the mouth of the case. Back the die up one full turn and set the large lock nut. This will leave a gap between the bottom of the die and shell holder. Next, lower the case and insert the bullet in the case mouth. Slowly run the case into the seater die. Check the bullet for proper seating depth. If the bullet is not seated properly, adjust the seater plug until the proper depth is obtained. Once the proper seating depth is attained, tighten the seater plug lock nut.

BULLET SEATING AND CRIMPING

For Roll Crimp

IMPORTANT: Please read instructions carefully. Do not adjust the seater die down against the shell holder as it will distort or crush the case. If the bullet you are using has a definite cannelure or crimping groove, the bullet can be seated and crimped using the following instructions. Before proceeding, cases must be trimmed to the same overall length to assure a consistent crimp. The crimping feature is machined into the seater die body. It is not a special attachment to the seater plug. The die must be moved up or down to obtain the proper crimp adjustment. To adjust the seater die, place a sized, primed and powder-charged case into the shell holder and run it to the top of the press stroke.

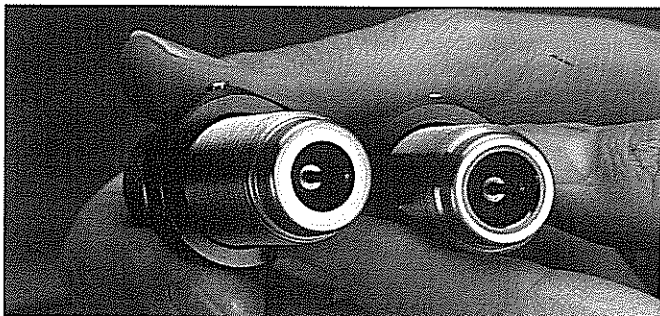

The standard RCBS steel die is shown on the left. The carbide insert is visible in the carbide sizer die on the right.

Screw the seater die into the press until you feel it touch the mouth of the case. Back the die up one full turn and set the large lock nut. This will leave a gap between the bottom of the die and the shell holder. Next, lower the case and insert a bullet in the case mouth. Slowly run the case and bullet into the seater die. Check the bullet for proper seating depth. If the bullet is not seated properly, adjust the seater plug until the proper depth is obtained. Next, adjust the die to crimp. While

the uncrimped cartridge is still in the seater die, unscrew the seater plug several turns. Screw the seater die downward until you feel it touch the mouth of the case. Lower the reloaded cartridge and adjust the seater die down about 1/8th of a turn. Run the reloaded cartridge into the die and then check the crimp. If more crimp is desired, repeat the preceding step by

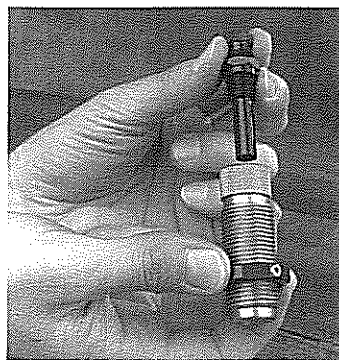

Some seater dies in our 3-die sets use a "through-the-top" style seater plug as shown in this photo. This style allows for easy cleaning.

adjusting the die downward 1/8th of a turn at a time. Over-crimping of the cartridge will cause bulging and may affect chambering. After you are satisfied with the crimp, set the large lock nut and run the completed cartridge into the seater die, then lower the seater plug until it touches the bullet. Tighten the seater plug lock nut. Once the seater die is properly adjusted, the bullet is seated and crimped in one operation.

BULLET SEATING AND CRIMPING

For Taper Crimp

IMPORTANT: Please read instructions carefully. Do not adjust the seater die down against the shell holder as it will distort or crush the case. Bullets for semi-automatic firearms are normally taper crimped because the cartridge headspaces on the mouth of the case and to assure proper feeding and functioning. (Note: Taper crimp seater dies are marked "TC" or "Taper Crimp" for easy identification.) The bullet can be seated and crimped using the following instructions. Before proceeding, cases must be trimmed to the same overall length to assure a consistent crimp. The crimping feature is machined into the seater die body. It is not a special attachment to the seater plug. The die must be moved up or down to obtain the proper crimp adjustment. To adjust the seater die, place a sized, primed and powder-charged case into the shell holder and run it to the top of the press stroke. Screw the taper crimp seater die into the press until you feel it touch the mouth of the case. Back the die up one full turn and set the large lock nut. This will leave a gap between the bottom of the die and the shell holder. Lower the case and insert a bullet into the case mouth. Slowly run the case up into the seater die. Check the bullet for proper seating depth. If the bullet is not seated properly, adjust the seater plug until the proper depth is obtained. Next, adjust the die to crimp. While the uncrimped cartridge is still in the seater die, unscrew the seater plug several turns. Then screw the seater die downward until you feel it touch the mouth of the case. Lower the reloaded cartridge and adjust the seater die down about 1/8th of a turn. Run the reloaded cartridge back into the seater die and check the crimp. If more crimp is desired, adjust the seater die down about 1/8th of a turn at a time. After you are satisfied with the crimp, set the large lock nut and run the completed cartridge into the seater die, then lower the seater plug until it touches the bullet. Tighten the seater plug lock nut. Once the seater die is properly adjusted, the bullet is seated and crimped in one operation.



RCBS Dies are tough, yet lightweight to handle any job.

FEATURES

RCBS Precisioneered Dies match tough steel to the tough jobs. The die bodies are machined and hardened until they're tough enough to meet our standards, yet smooth enough to baby the most delicate brass case.

Sizer dies for bottleneck cases are vented, when required, to avoid case damage caused by trapped air, and are made to absolutely precise tolerances. Expander decapping units are made in three pieces instead of one, so one piece can be replaced without buying a whole new unit. And there's extra muscle where it counts, in the decapping pin. Seater dies have a unique design which aligns the bullet with the case mouth an instant before seating. Interior polishing helps brass work smoothly with very little friction and cannot chip or peel with age.

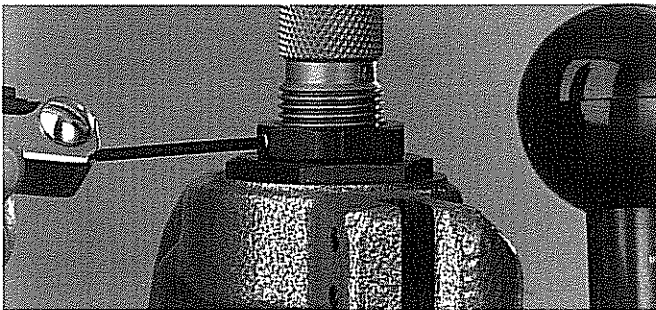

Once the die has been adjusted, tighten the setscrew to hold the proper setting.

All RCBS dies feature an improved steel lock nut with a "hex" design that allows even tighter control over precise adjustments. A solid brass setscrew locks the nut securely, yet will not damage the die threads. Once the large lock nut on the die is set, it can be locked in the desired position by tightening the setscrew. The die will then hold the proper setting and may be reused without readjustment.

A piece of lead shot under the set screw may prevent accidental stripping of the set screw. Most RCBS dies are manufactured with the standard 7/8"-14 thread and are designed for use with a shell holder having a lip thickness of 0.125". The primary exceptions are the .45 Auto Rimmed, 11mm (.43) Mauser and .43 Spanish. These must have a shell holder lip thickness of 0.150". Any variations of these dimensions may cause headspace or insufficient sizing problems.

PACKAGING

All RCBS dies are packaged in convenient plastic storage boxes specially designed by RCBS to protect your dies in shipment

and during storage. A unique cradle holds the dies firmly in place to prevent damage and rolling around. Each box contains a label for recording your favorite loads and can be mounted on the inside lid for quick reference. A label on the outside of the box lists the die caliber for easy identification.

CUSTOMER SERVICE



A label is provided with each die box for recording your favorite loads.

All RCBS dies are carefully checked and thoroughly inspected before shipping. Each die will reload fired cases from any standard chamber of the caliber stamped on the die. Should the die perform unsatisfactorily, call or write to RCBS, explaining the problem in detail. Be sure to mention the caliber of dies and the year of manufacture. In most cases we can help you overcome the problem without the inconvenience and expense of returning the dies. If necessary, we will authorize the return of the dies. Do not attempt to alter the dies in any way.

Seater plugs are designed to fit most bullets of a given caliber. However, it is impossible to make one seater plug to fit every possible variation in bullet style and weight. If the seater plug furnished with the seater die does not fit the bullet you are using, check the list of Alternate Seater Plugs for special application in the current RCBS Reloading Catalog. If you are unable to find the one you need, a custom seater plug will have to be produced. Please provide us with two sample bullets—both will be returned with the new seater plug—along with your order and payment. Be sure to specify caliber and 1/4"-28 or 1/2"-20 thread size. Call, e-mail or write RCBS Customer Service for current price so that you can include payment and avoid any unnecessary delay. Note: We do not keep bullets on file, so you must send samples to guarantee a perfect fit.

Send your order and payment with securely packed sample bullets to:

RCBS Customer Service
Custom Seater Plug
605 Oro Dam Blvd.
Oroville, CA 95965-5718

A case stuck in the sizer die may be removed with an RCBS Stuck Case Remover—available from your RCBS dealer. Or you may return the sizer die along with your name and address. We will remove the stuck case or replace the die under terms of the RCBS Lifetime Warranty.

PREPARING THE DIES

Some sizer dies for bottleneck type cases contain a small vent hole through which trapped air escapes during resizing. Sometimes the vent hole will plug up with factory polishing material. This material will scratch and dent cases unless it is removed. To clean, unscrew the decap unit from the die. Insert

a straightened paper clip, needle or similar object into the vent hole. This will push the material into the die body. The debris can then be easily removed by cleaning the inside of the die using a patch saturated with Outers Solvent. Reassemble the die.

IMPORTANT: We find that most scratching of the interior of a die is caused by nickel cases or grit on the brass surface. If you

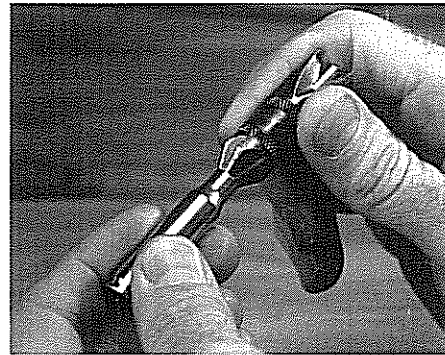

Lightly chamfer the case mouth with a Deburring Tool to remove rough edges for easier bullet seating.

are using nickel pistol cases, we recommend that you use a carbide sizer die. This die is hard enough to resist the scratching that nickel cases cause. The best method for cleaning grit from brass cases is to tumble them. Tumbling the cases will clean the surface and prevent scratching the internal die

surface. Your cases should be cleaned periodically to protect both your dies and the chamber of your firearms. The RCBS Sidewinder Case Tumbler and Vibratory Case Cleaner are recommended for cleaning cases.

Before storing dies, lightly spray them with Outers Tri Lube or Metal Seal to protect them from rust.

PREPARING THE CASES

Clean and inspect cases before lubricating and sizing. Discard any cases with indications of a split neck or partial head separation. Check cases for the correct overall length. If necessary, **trim after sizing**. If bullets are to be crimped, it is imperative that cases be trimmed to the same overall length. Trimmed case mouths should be deburred and lightly chamfered inside and out with an RCBS Deburring Tool or use of a RCBS Three Way Cutter in your case trimmer.

Cases must be properly lubricated before sizing. Over-lubrication will result in a dented case shoulder. Improper or no lubrication will result in a case stuck in the sizer die. For best results use RCBS Case Lube-2 applied to an RCBS Case Lube Pad or Case Slick. Case mouths should be very lightly lubricated with an RCBS Case Neck Brush. These accessories are available from your dealer as individual items or combined in the RCBS Case Lube Kit. Do not lubricate the shoulders of bottle-neck type cases. After the cases are lubricated they are ready to go through the reloading steps.

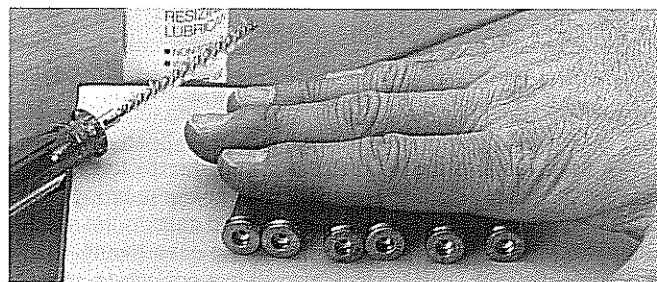

Roll cases on an RCBS Case Lube Pad for proper lubrication.

PARTS LIST FOR 2 DIE SETS

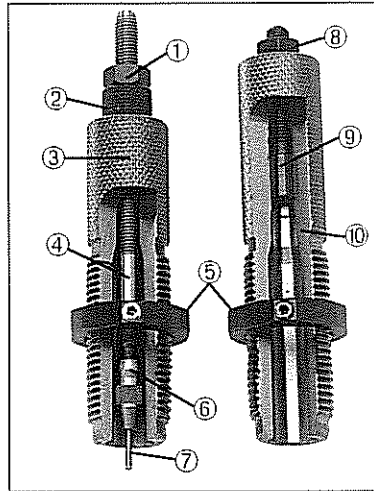

REPLACEMENT PARTS

The Expander-Decapping Unit (Key 4, 6, & 7) and Decapping Pins (Key 7) may be available from your dealer. If not, they and all other replacement parts should be ordered from RCBS Customer Service. See the back panel of this instruction booklet for phone number or address.

KEY	PART #	DESCRIPTION
1	09604	Lock Nut 1/4-28
1	09603	Lock Nut 10-32
2	-	Guide Bushing
3	-	Sizer Die Body
4	-	Expander Decapping Rod
5	87501	Die Lock Nut, 7/8-14
6	-	Expander Ball
7	-	Decapping Pin
8	09604	Lock Nut 1/4-28
9	-	Seater Plug
10	-	Seater Die

PARTS LIST FOR 3 DIE SETS

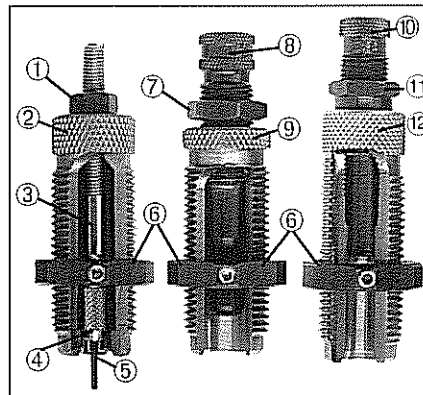

REPLACE- MENT PARTS

The Decapping Unit (Key 3, 4, & 5) and Decapping Pins (Key 5) may be available from your dealer. If not, they and all other replacement parts should be ordered from RCBS Customer Service. See the back panel of this instructions booklet for phone number or address.

KEY	PART #	DESCRIPTION
1	09604	Lock Nut, 1/4-28
2	-	Sizer Die
3	-	Decapping Rod
4	-	Decap Pin Holder
5	-	Decapping Pin
6	87501	Lock Nut, 7/8-14
7	09615	Lock Nut, 9/16-18
8	-	Expander
9	-	Expander Die Body
10	-	Seater Plug
11	90000	Lock Nut 1/2-20
11	09604	Lock Nut 1/4-28
12	-	Seater Die