



**Your Shooting Partner**

CCI,<sup>®</sup> Speer,<sup>®</sup> RCBS,<sup>®</sup> Outers<sup>®</sup> & Weaver<sup>®</sup>

We think that we make the very best reloading equipment in the world. If you agree, please tell your friends. If you disagree, tell us -- we want to do something about it!

For Customer Service call toll free: 1-800-533-5000

Hours: Monday - Thursday 6:30 A.M. - 4:30 P.M.

**SPORTING EQUIPMENT DIVISION OF BLOUNT, INC.**  
RCBS Operation, 605 Oro Dam Blvd., Oroville, CA 95965

FORM #200503-1290



**RAM  
PRIMING  
UNIT**

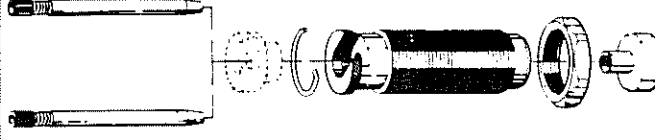

## WARNING: PRIMERS WILL EXPLODE!

1. Keep primers away from children.
2. Do not smoke near primers.
3. Primers are designed to explode and will do so when subjected to heat or percussion.
4. Always wear safety glasses when handling primers.
5. Do not force primers. All primers in the near vicinity of an exploding primer will usually also detonate violently. Do not store or handle primers in bulk.
6. For identification and safety, keep primers in their original protective packaging.
7. An absolute minimum of primers should be kept at the loading operation. Open only one package tray at a time.
8. Do not decap live primers.
9. Do not attempt to seat, or reseal, a primer in a loaded round.

### Priming with the Ram™ Priming Unit

The Ram Priming Unit is offered as an alternative to hand held or bench-mounted priming tools. The unit includes the Ram Priming Body, Primer Rod Holder, large and small Primer Rod Assemblies, Hex Lock Nut and Shell Holder Spring. The Ram Priming Body threads into the 7/8"-14 press hole and accepts standard Shell Holders. The Primer Rod Holder snaps into the press ram and holds the Primer Rod Assembly.

Described here are two methods for primer seating using the Ram Priming Unit. Priming should be accomplished following either procedure precisely.

The first method of primer seating, known as "seating primers by feel," is as follows:

1. Remove conventional Shell Holder from ram.
2. Install Primer Rod Holder in ram.
3. Thread the Ram Priming Body into the press, positioning it so the Hex Lock Nut is even with the top of the threads of the body and so the shell holder slot is facing the front. Secure by tightening the Hex Lock Nut.

### RAM™ PRIMING UNIT PARTS LIST

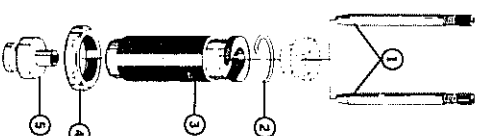

KEY	PART NO.	DESCRIPTION
1	09471	Primer Rod Assembly, Lg. & Sm.
2	09111	Shell Holder Spring
3	09175	Ram Priming Body
4	87505	Hex Lock Nut 7/8"-14
5	09176	Primer Rod Holder

Standard Shell Holder not supplied with Ram Priming Unit.

Fig. 1

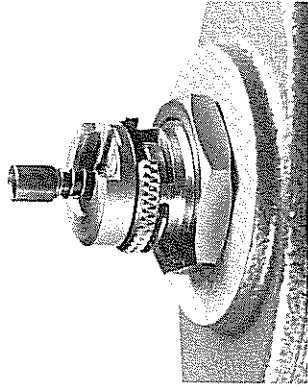

4. Insert appropriate Shell Holder (not supplied) into Ram Priming Body.
5. Assemble large or small Primer Rod Assembly as appropriate. To assemble the Primer Rod Assemblies: Select the correct primer plug and sleeve (large or small). Drop the primer plug through the sleeve. Place the spring on top of the primer rod. Screw the primer plug into the top of the primer rod. Tighten the assembly with a small nail or straightened paper clip through the hole in the primer plug. Do not over-tighten.

6. Position the ram at the top of its stroke and drop the Primer Rod Assembly through the Shell Holder. It should come to rest extending approximately 1/2 inch above the Shell Holder (see fig. 1).

To prime simply place the primers into the extended Primer Rod Assembly (see fig. 2). Raise the operating handle of the press slightly, so that the Primer Rod Assembly has dropped below the level of the Shell Holder. Insert deprimed cartridge case (see fig. 3) and lower the operating handle until the primer is seated. Proper primer seating requires that the primer be seated between .002 inch and .006 inch below the case head. Both insufficient and excessive primer seating depth greatly decrease primer sensitivity and can result in misfires. Due to the mechanical advantages of most presses, it is possible to over-seat or crush primers during seating. Great care must be exercised until you learn the proper "feel."

Fig. 2



The second and perhaps more precise method of primer seating, known as "seating primers to a positive stop," is as follows:

7. Repeat steps 1-6.
8. Loosen the Hex Lock Nut and unscrew the Ram Priming Body approximately 1/2 inch until proper primer seating is achieved exactly at the end of the ram stroke. Proper adjustment can be achieved only by trial and error.

Fig. 3

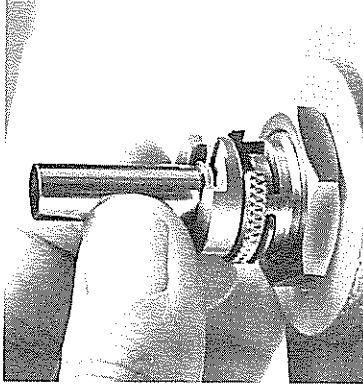

Subsequent primer seating depth using this second method will vary only as much as the variation in the rim thickness of your cartridge cases.

Again, priming should be accomplished following either procedure precisely.

## **WARNING: PRIMERS WILL EXPLODE!**

1. Keep primers away from children.
2. Do not smoke near primers.
3. Primers are designed to explode and will do so when subjected to heat or percussion.
4. Always wear safety glasses when handling primers.
5. Do not force primers in the near vicinity of an exploding primer. Primers will usually also detonate violently. Do not store or handle primers in bulk.
6. For identification and safety, keep primers in their original protective packaging.
7. An absolute minimum of primers should be kept at the loading operation. Open only one package tray at a time.
8. Do not decap live primers.
9. Do not attempt to seal, or reseal, a primer in a loaded round.

### **Priming with the Ram™ Priming Unit**

The Ram Priming Unit is offered as an alternative to hand held or bench-mounted priming tools. The unit includes the Ram Priming Body, Primer Rod Holder, large and small Primer Rod Assemblies, Hex Lock Nut and Shell Holder Spring. The Ram Priming Body threads into the 7/8-14 press hole and accepts standard Shell Holders. The Primer Rod Holder snaps into the press ram and holds the Primer Rod Assembly.

Described here are two methods for primer seating using the Ram Priming Unit. Priming should be accomplished following either procedure precisely.

The first method of primer seating, known as "sealing primers by feel," is as follows:

1. Remove conventional Shell Holder from ram.
2. Install Primer Rod Holder in ram.
3. Thread the Ram Priming Body into the press, positioning it so the Hex Lock Nut is even with the top of the threads of the body and so the shell holder slot is facing the front. Secure by tightening the Hex Lock Nut.