

RCBS[®]

Model 5•0•2 Scale Instructions

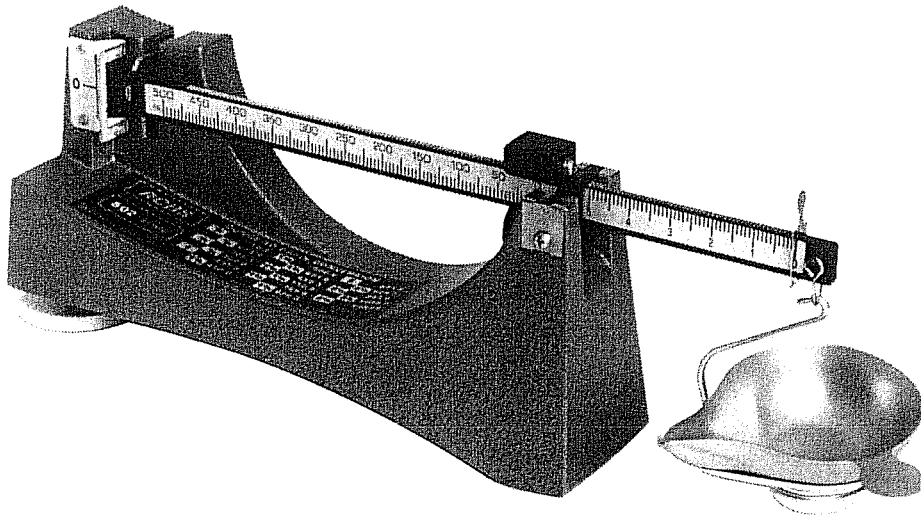

IMPORTANT

Since the powder charge is the most critical portion of a reloaded cartridge, it is very important that you take a few minutes to read these instructions carefully to gain an understanding of the use of the two poise system before attempting to weigh powder charges.

SAFETY

Reloading is an enjoyable and rewarding hobby that is easily conducted with safety. But carelessness or negligence can make reloading hazardous. This product has been designed from the beginning with the user's safety in mind.

As with any reloading operation, some safety rules must be followed. By observing these few rules, the chance of a hazardous occurrence causing damage or injury becomes extremely remote.

GENERAL

- Use the reloading equipment as the manufacturer recommends. Study the instructions carefully and become thoroughly familiar with the operation of the product. Don't take short cuts.
- Observe "good housekeeping" in the reloading area. Keep tools and components neat, clean and orderly. Promptly and completely clean up primer and powder spills.
- Reload only when you can give your undivided attention. Do not reload when fatigued or ill. Develop a reloading routine to avoid mistakes. Avoid haste — load at a leisurely pace.
- Always wear adequate eye protection. You assume unnecessary risk when reloading without wearing safety glasses.

LOADING DATA

- Use only laboratory tested reloading data.
- OBSERVE ALL WARNINGS ABOUT THE USE OF MAXIMUM LISTED LOADS.

PRIMERS AND POWDER

- Store primers and powder beyond the reach of children and away from heat, dampness, open flames and electrical equipment.
- DO NOT use primers of unknown identity. To destroy unwanted primers, soak in oil for a few days and then bury.
- Keep primers in original factory container until ready to use. Return unused primers to the same factory packaging for safety and to preserve their identity.
- DO NOT store primers in bulk. The blast of just a few hundred primers is sufficient to cause serious injury to anyone nearby.
- DO NOT force primers. Use care in handling primers.
- DO NOT use any powder unless its identity is positively known. Discard all mixed powders and those of uncertain or unknown identity.
- If you use a powder measure, replace the lids on both the powder hopper and powder can after the powder hopper has been filled.
- Before charging cases, settle the powder in the powder hopper. Throw and check the weight of at least ten charges. This will assure you that the correct powder charge is being thrown.
- After a reloading session ends, pour the remaining powder back in its original factory container. This will preserve the identity and shelf life of the powder.
- DO NOT smoke while handling powder or primers.

RECORD KEEPING

- Keep complete records of reloads. Apply a descriptive label to each box.

Since Omark Industries has no control over the choice of components, the manner in which they are assembled, the use of this product, or the guns in which the resulting ammunition may be used, no responsibility, either expressed or implied, is assumed for the use of ammunition reloaded with this product.

IMPORTANT

Please read these instructions very carefully in order to obtain optimum results. Save these instructions for future reference.

UNPACKING AND SETUP

Your "5 • 0 • 2" scale is packed in a specially designed carton to provide maximum protection. Unpack the scale carefully to avoid damaging components. (See illustration below)

Place the base on a reasonably flat and level surface.

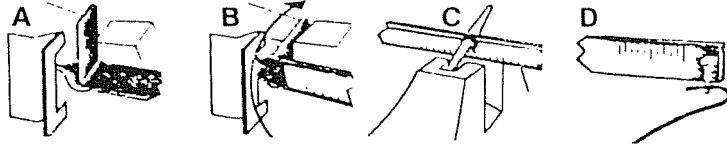

To position the beam in the base, hold it horizontally with the copper damper vane pointing upward, as shown in (A). Slide the pointer end of the beam behind the right edge of the dial plate. Rotate the beam, as shown in (B), so that the damper vane moves into the slot in the housing. Lower the center pivot onto the bearings as illustrated in (C). Hook the pan bow in the end loop on the extreme right of the beam, illustration (D). Put the pan in place.

Note the way the pan support cradles the pan. This feature makes it possible to weight long, heavy objects such as cases and loaded cartridges without tipping the pan off its support. The pan support may also be rotated within the wire hanger for a more convenient handle position.

Your "5 • 0 • 2" is now ready for use.

CAUTION!

The end loop **MUST** not be bent or twisted when unpacking.

In order for the scale to operate properly:

- Both sides of the end loop **MUST** be parallel to the beam.
- The end loop shall move freely in the pivot notches and hang in a position perpendicular to the knife edges.

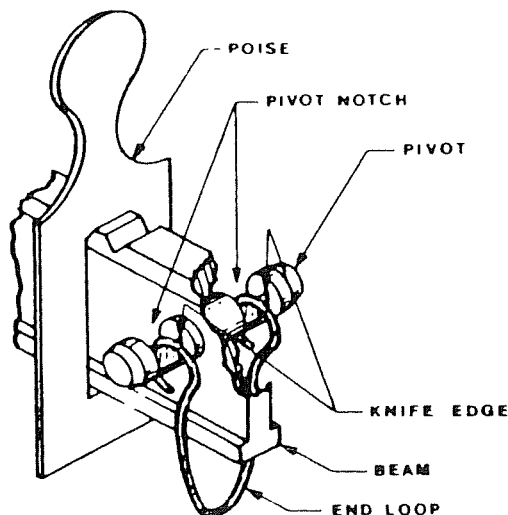

About your RCBS Model 5 • 0 • 2

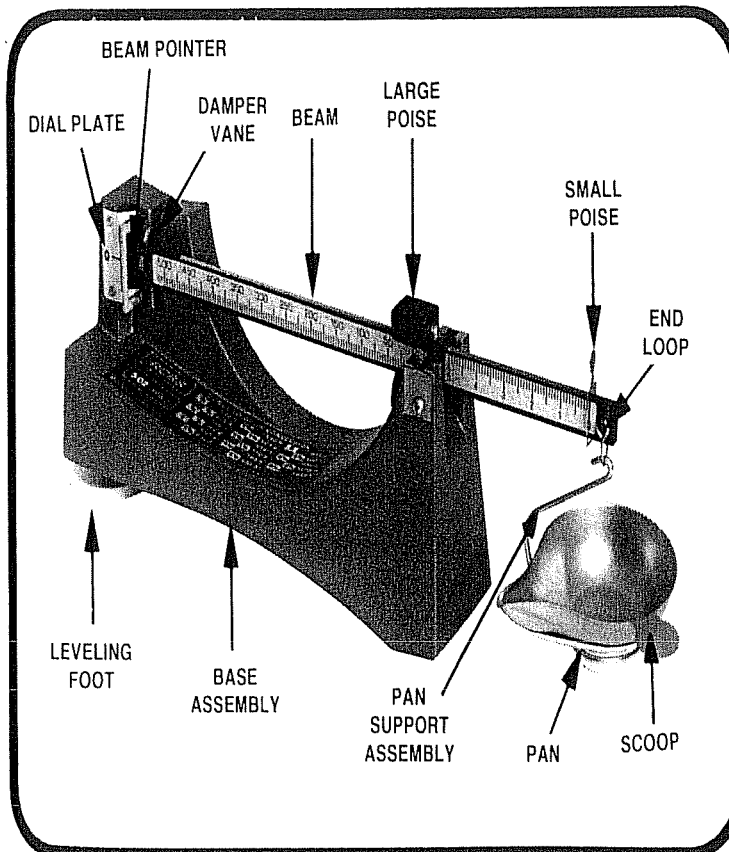

The 5 • 0 • 2 has a 505 grain capacity, and features a two poise system. Calibrations on left side of beam are in full 5 grain increments. The smaller poise on right side of beam adjusts from 0.1 to 5 grains. This was the first reloading scale to utilize *magnetic damping* to eliminate unnecessary beam oscillation. It has a rugged die-cast base with a large leveling leg for extra stability on the bench. Self-aligning *agate bearings* support the hardened steel beam pivots to guarantee sensitivity of 0.1 grain.

This scale is manufactured exclusively for RCBS by

*Ohaus Corporation
29 Hanover Road
Florham Park, N.J. 07932
Telephone (973) 377-9000 (in New Jersey)
Toll Free (800) 526-0659*

HOW TO USE THE LARGE POISE (500 GRAIN)

The principle of the large poise consists of an accurately adjusted weight which moves parallel to the longitudinal axis of the beam and which is positioned at weight values by means of a pawl engaging notches in the beam. The poise run is from 0 to 500 grains. The equally-spaced notches divide this distance into 100 equal parts so that each subdivision is equivalent to 5 grains of weight.

To zero the large poise, move it to the position where the pawl, located on the right side of the poise, engages the first notch on the right end of the poise travel. The poise indicator will line up with the zero graduation.

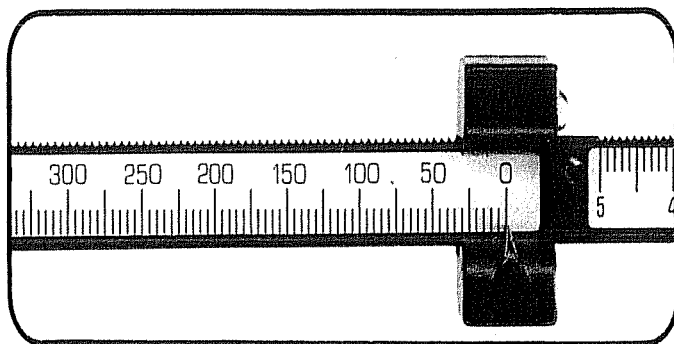

To increase weight values, move the poise to the left and line up the indicator with the desired graduation. **Always make sure the pawl is seated in the notch.**

Illustrated is a setting of 160 grains.

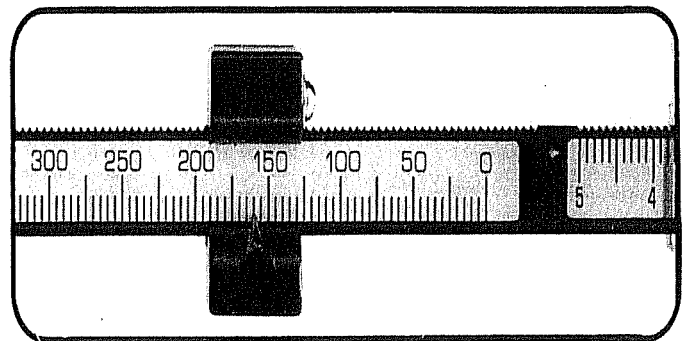

Do not attempt to set the large poise at any position except firmly seated in a notch. Always use the smaller poise for weight values between the 5 grain increments of the large poise.

HOW TO USE THE SMALL POISE (5 GRAIN)

The principle of the small poise is the same as for the large poise. This poise run is from 0 to 5 grain. The equally spaced notches divide this distance into 50 equal parts so that each subdivision is equivalent to 1/10th (.1) grain of weight.

To zero the small poise, move it to the position where the pawl, which is the top edge of the rectangular slot through the poise, engages the notch directly above the zero graduation. The long, vertical edge of the poise is the indicator and will line up with the zero graduation.

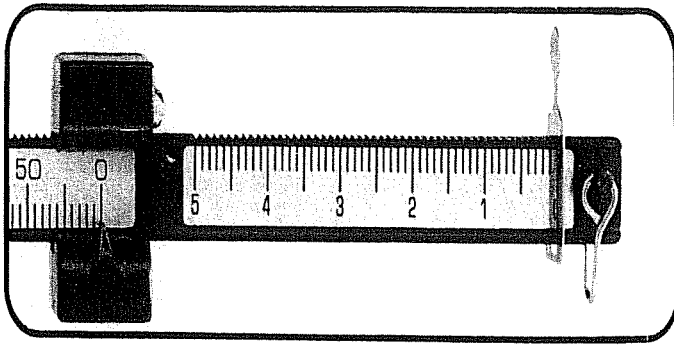

To increase weight values, move the poise to the left and line it up with the desired graduation. **Always make sure the pawl is seated in the notch.**

Illustrated is a setting of 3.7 grains.

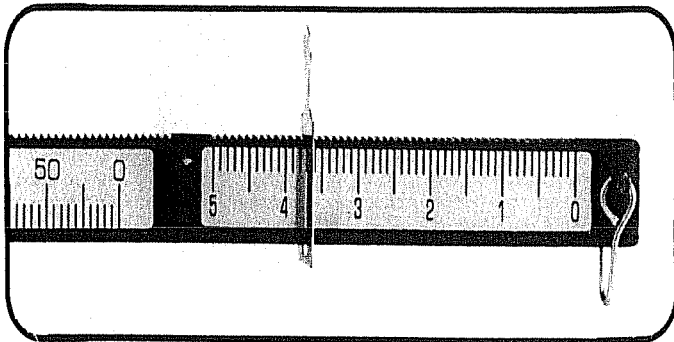

Do not attempt to set the poise at any position except firmly seated in a notch.

HOW TO ZERO BALANCE THE SCALE

Place both poises at zero. If the scale has been placed on a reasonably level surface, the beam pointer will come to rest fairly close to the zero graduation on the dial plate. Raise or lower the left end of the base by means of the leveling foot to line them up.

The scale should be zero balanced before use and checked periodically during use for maximum accuracy and protection against error.

MAGNETIC DAMPING

Your "5 • 0 • 2" scale is equipped with magnetic damping which causes the beam to come to rest quickly without affecting sensitivity or accuracy.

It operates on the principle of a permanent magnetic field resisting the motion of a non-magnetic, copper damper vane attached to the beam.

The damping magnets are positioned inside the base on both sides of the slot that the damper vane travels in.

The only maintenance required is to keep this slot free of magnetic particles which could interfere with free movement of the damper vane.

The magnetic damping is effective at all loads and will speed up weighing.

HOW TO WEIGH

To weigh an unknown, such as the throw of charge from a powder measure, place it in the scale pan. Move the large poise to the first notch which causes the beam pointer to drop below zero and then move it back one notch. Then move the small poise to the notch which brings the beam pointer closest to zero. The weight of the unknown is the sum of the two poise readings.

Illustrated is a total weight of 163.7 grains.

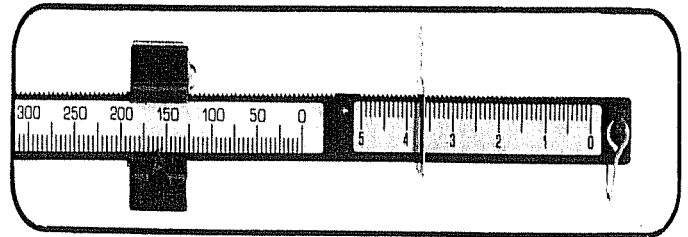

The scale can also be used to weigh out predetermined powder charges, either alone or in combination with a powder measure set to throw a light charge.

In either case the desired final weight of the charge is preset on the poises. This will cause the beam pointer to fall below the zero graduation. Add powder to the pan until the beam balances.

When making repeated weighings in this manner, avoid weighing errors by making sure that the poises remain in their correct positions and are not accidentally moved.

HOW TO CARE FOR YOUR SCALE

Keep the scale clean at all times and be particularly careful to prevent the accumulation of dirt on the pivots and bearings. Never apply oil or any lubricant to the pivots or bearings; this will lower the accuracy of the scale.





Your Shooting Partner

CCI, Speer, RCBS, Outers & Weaver

We think that we make the very best reloading equipment in the world. If you agree, please tell your friends. If you disagree, tell us – we want to do something about it!

For Customer Service call toll free: 1-800-533-5000

Hours: Monday-Thursday 7:00 A.M. - 4:30 P.M.

SPORTING EQUIPMENT DIVISION OF BLOUNT, INC.

RCBS Operation, 605 Oro Dam Blvd., Oroville, CA 95965