

RCBS[®]

**LITTLE DANDY
PISTOL POWDER MEASURE**



PRODUCT INSTRUCTIONS

SAFETY

Reloading is an enjoyable and rewarding hobby that is easily conducted with safety. But carelessness or negligence can make reloading hazardous. This product has been designed from the beginning with the user's safety in mind.

As with any reloading operation, safety rules must be followed. By observing these few rules, the chance of a hazardous occurrence causing damage or injury becomes extremely remote.

GENERAL

- Use the equipment as the manufacturer recommends. Study the instructions carefully and become thoroughly familiar with the operation of the product. Don't take short cuts.
- Observe "good housekeeping" in the work area. Keep tools and components neat, clean and orderly. Promptly clean up any powder spills.
- Always wear adequate eye protection.
- If any unusual resistance is encountered when moving the operating handle, STOP IMMEDIATELY and investigate the cause. To proceed against unusual resistance may damage equipment and/or cause serious injury!

LOADING DATA

- Use only laboratory tested data. We highly recommend the use of the SPEER Reloading Manual.
- OBSERVE ALL WARNINGS ABOUT THE USE OF MAXIMUM LISTED LOADS.

POWDER HANDLING

- Store primers and powder beyond the reach of children and away from heat, dampness, open flames and electrical equipment.
- DO NOT use any powder unless its identity is positively known. Discard all mixed powders and those of uncertain or unknown identity.
- Before charging cases, settle the powder in the powder hopper. Throw and check the weight of at least ten charges. This will assure you that the correct powder charge is being thrown.
- After a reloading session ends, pour the remaining powder back in its original factory container. This will preserve the identity and shelf life of the powder.
- DO NOT smoke while handling powder or primers.
- DO NOT use black powder in this measure.

RECORD KEEPING

- Keep complete records of reloads. Apply a descriptive label to each box showing the date produced, and the primer, powder and bullet used. Labels for this purpose are packed with SPEER bullets.

Since RCBS has no control over the choice of components, the manner in which they are assembled, the use of this product, or the firearms in which the resulting ammunition may be used, no responsibility, either expressed or implied, is assumed for the use of ammunition reloaded with this tool.

GENERAL INFORMATION

In one-half turn of the rotor, the RCBS Little Dandy Pistol Powder Measure will charge cases within a fraction of a grain. Large and small threaded drop tubes are provided that permit a proper fit on cases from .22 to .45 caliber. Rotors with different sized cavities are available for this measure. Cases can be charged quite rapidly by hand-holding the measure over cases in a loading block. The measure body is threaded 7/8 x 14 and may be used with the optional Powder Measure Stand (part #09035) or the Powder Measure Stand Plate (part #09020).

Like other powder measures, this is a volume metering device. It is imperative that the charges be checked with an accurate powder scale. This will assure that the correct charge is being thrown. Consult the Rotor Charge Table for the correct rotor to use.

TO ASSEMBLE

Back the Rotor Guide Screw out of the body enough to clear the rotor hole. Clean the inside body with a clean, dry cloth. Never use grease or any other type lubricant on the pistol powder measure. Insert the rotor into the body with the slot aligned with the screw hole and tighten the screw. Thread the appropriate drop tube into the bottom of the powder measure.

TO CHANGE OR REMOVE A ROTOR

Back the Rotor Guide Screw out about halfway and withdraw the rotor. If the rotor is difficult to remove from the pistol powder measure, *do not* force it. Return the complete unit to RCBS for service.

TO SELECT A ROTOR

NOTE: The rotor number does not indicate the charge weight of a given powder. It is simply a reference number. Refer to the Rotor Charge Table for the type and amount of powder that each rotor will throw.

CAUTION: The Rotor Charge Table is not a table of recommended loads for pistol cartridges; it is merely a table of equivalents of various powders adapted to pistol cartridges. For recommended loads, consult the Speer Reloading Manual. Keep in mind that volume/weight ratios may sometimes vary with different lots of the same powder. Again check powder charges on an accurate powder scale before charging cases.

TO USE

Be sure the rotor cavity is clean and the appropriate rotor has been installed. Then fill the hopper with the correct powder and replace the cap. Throw several charges to settle the powder, then weigh several more charges with your powder scale. Place the powder measure over the case with the drop tube touching the case mouth. Then throw the powder charge by rotating the knurled end of the rotor. Operate the measure in a smooth, uniform manner. When finished charging cases, visually inspect them to see that all cases have the same level of powder. When you have completed charging the cases, return the unused powder to the powder can and clean the powder measure. Do not leave powder in the measure.

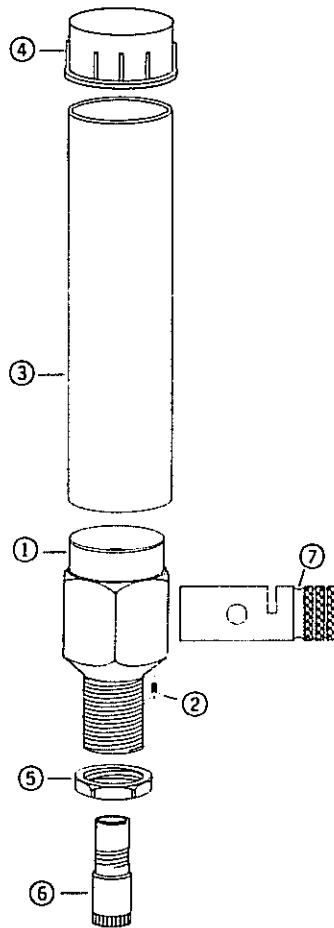

KEY	PART #	DESCRIPTION
1	86041	Pistol Powder Measure Body
2	86042	Rotor Guide Screw
3	86043	Pistol Powder Measure Hopper
4	86044	Pistol Powder Measure Hopper Cap
5	87505	Hex Lock Nut 7/8-14
6	09022	Drop Tube, Large
6	09023	Drop Tube, Small
7	-	Rotor

LITTLE DANDY ROTOR CHART					
ROTOR #	PART #	ROTOR #	PART #	ROTOR #	PART #
1	86001	10	86010	19	86019
2	86002	11	86011	20	86020
3	86003	12	86012	21	86021
4	86004	13	86013	22	86022
5	86005	14	86014	23	86023
6	86006	15	86015	24	86024
7	86007	16	86016	25	86025
8	86008	17	86017	26	86026
9	86009	18	86018		

ROTOR CHARGE TABLE FOR LITTLE DANDY PISTOL POWDER MEASURE NOMINAL ROTOR CHARGE WEIGHTS (GRAINS)

Part Number	86036	86035	86001	86002	86003	86004	86005	86006	86007	86008	86009	86010	86011	86012	86013	86014	86015	86016	86017	86018	86019	86020	86021	86022	86023	86024	86025	86026
Rotor Number	00	0	1	2	3	4	5	6	7	8	9	10	11	12	13	14	15	16	17	18	19	20	21	22	23	24	25	26
Bullseye	1.7	2.2	2.5	2.7	3.0	3.2	3.5	3.7	4.0	4.5	5.0	5.5	6.0	6.5	7.2	7.8	8.4	9.0	9.7	NR	NR	NR	NR	NR	NR	NR	NR	
231	NR	NR	2.7	3.0	3.3	3.6	3.9	4.2	4.5	5.0	5.6	6.2	6.8	7.2	7.9	8.6	9.3	10.0	10.6	11.3	12.1	NR	NR	NR	NR	NR	NR	
HP38	NR	NR	2.8	3.0	3.4	3.6	4.0	4.2	4.5	5.1	5.5	6.2	6.8	7.5	7.9	8.8	9.4	10.3	10.9	11.7	12.3	NR	NR	NR	NR	NR	NR	
Red Dot	NR	NR	1.7	1.9	2.2	2.3	2.5	2.6	2.9	3.2	3.6	4.0	4.3	4.7	5.1	5.5	6.0	6.5	6.9	7.4	7.8	8.3	8.7	9.1	NR	NR	NR	
700-X	NR	NR	2.0	2.2	2.4	2.6	2.8	3.0	3.2	3.6	4.0	4.4	4.8	5.1	5.7	6.2	6.8	7.3	7.7	8.2	8.7	9.2	NR	NR	NR	NR	NR	
Green Dot	NR	NR	1.9	2.1	2.3	2.5	2.8	3.0	3.1	3.5	3.9	4.4	4.8	5.1	5.5	6.1	6.6	7.0	7.5	8.0	8.8	9.9	9.6	10.0	10.5	10.7	11.4	
SR4756	NR	NR	NR	NR	NR	NR	NR	NR	NR	NR	NR	NR	NR	NR	NR	NR	NR	NR	NR	NR	NR	NR	NR	NR	NR	NR	NR	
HS-5	NR	NR	4.2	4.5	5.0	5.3	5.9	6.2	6.6	7.4	8.2	9.0	NR	NR	NR	NR	NR	NR	NR	NR	NR	NR	NR	NR	NR	NR	NR	
Unique	NR	NR	2.3	2.5	2.8	3.0	3.3	3.5	3.7	4.2	4.7	5.2	5.7	6.0	6.6	7.2	7.8	8.4	9.0	9.5	10.1	10.7	11.3	11.8	12.4	13.1	NR	
SR7625	NR	NR	2.5	2.7	3.0	3.2	3.5	3.8	4.0	4.5	5.0	5.5	6.0	6.5	7.2	7.7	8.3	9.0	9.6	NR	NR	NR	NR	NR	NR	NR	NR	
HS-6	NR	NR	NR	NR	NR	NR	NR	NR	NR	NR	NR	NR	NR	NR	NR	NR	NR	NR	NR	NR	NR	NR	NR	NR	NR	NR	NR	
HS-7	NR	NR	NR	NR	NR	NR	NR	NR	NR	NR	NR	NR	NR	NR	NR	NR	NR	NR	NR	NR	NR	NR	NR	NR	NR	NR	NR	
Herco	NR	NR	NR	NR	NR	NR	NR	NR	NR	NR	NR	NR	NR	NR	NR	NR	NR	NR	NR	NR	NR	NR	NR	NR	NR	NR	NR	
Blue Dot	NR	NR	NR	NR	NR	NR	NR	NR	NR	NR	NR	NR	NR	NR	NR	NR	NR	NR	NR	NR	NR	NR	NR	NR	NR	NR	NR	
G30	NR	NR	NR	NR	NR	NR	NR	NR	NR	NR	NR	NR	NR	NR	NR	NR	NR	NR	NR	NR	NR	NR	NR	NR	NR	NR	NR	
2400	NR	NR	NR	NR	NR	NR	NR	NR	NR	NR	NR	NR	NR	NR	NR	NR	NR	NR	NR	NR	NR	NR	NR	NR	NR	NR	NR	
H110	NR	NR	NR	NR	NR	NR	NR	NR	NR	NR	NR	NR	NR	NR	NR	NR	NR	NR	NR	NR	NR	NR	NR	NR	NR	NR	NR	
296	NR	NR	NR	NR	NR	NR	NR	NR	NR	NR	NR	NR	NR	NR	NR	NR	NR	NR	NR	NR	NR	NR	NR	NR	NR	NR	NR	
SR4795	NR	NR	NR	NR	NR	NR	NR	NR	NR	NR	NR	NR	NR	NR	NR	NR	NR	NR	NR	NR	NR	NR	NR	NR	NR	NR	NR	
IMR 4227	NR	NR	NR	NR	NR	NR	NR	NR	NR	NR	NR	NR	NR	NR	NR	NR	NR	NR	NR	NR	NR	NR	NR	NR	NR	NR	NR	
680	NR	NR	NR	NR	NR	NR	NR	NR	NR	NR	NR	NR	NR	NR	NR	NR	NR	NR	NR	NR	NR	NR	NR	NR	NR	NR	NR	
IMR 4198	NR	NR	NR	NR	NR	NR	NR	NR	NR	NR	NR	NR	NR	NR	NR	NR	NR	NR	NR	NR	NR	NR	NR	NR	NR	NR	NR	
H322	NR	NR	NR	NR	NR	NR	NR	NR	NR	NR	NR	NR	NR	NR	NR	NR	NR	NR	NR	NR	NR	NR	NR	NR	NR	NR	NR	
Re-7	NR	NR	NR	NR	NR	NR	NR	NR	NR	NR	NR	NR	NR	NR	NR	NR	NR	NR	NR	NR	NR	NR	NR	NR	NR	NR	NR	
Accurate Arms #2	NR	NR	3.1	3.3	3.9	4.2	4.6	4.8	5.1	5.6	6.2	6.8	7.6	8.4	9.4	10.0	10.5	11.2	12.1	12.9	13.9	15.0	16.0	16.5	16.9	18.3	19.0	
Accurate Arms #5	NR	NR	4.0	4.3	4.8	5.1	5.6	5.9	6.3	7.1	7.8	8.6	9.3	10.3	11.3	12.2	13.2	14.2	15.2	16.1	17.1	18.0	18.9	19.8	20.8	21.9	23.0	
Accurate Arms #7	NR	NR	4.2	4.6	5.1	5.4	6.0	6.3	6.6	7.5	8.3	9.1	9.9	11.0	12.0	13.0	14.0	15.0	16.0	17.0	18.0	19.0	20.0	20.9	22.0	23.1	24.3	
Accurate Arms #9	NR	NR	4.2	4.5	5.0	5.3	5.9	6.2	6.6	7.4	8.1	9.0	9.6	10.8	11.9	12.8	13.8	14.9	15.8	16.8	17.8	18.8	19.8	20.7	21.8	22.9	24.1	
Olin 473AA	NR	NR	2.8	3.1	3.4	3.7	4.0	4.2	4.5	5.0	5.5	6.1	6.6	7.4	8.1	8.7	9.3	9.9	10.9	11.4	12.1	12.8	13.3	14.1	15.0	15.5	16.4	
Olin 452AA	NR	NR	2.4	2.5	2.8	3.0	3.2	3.4	3.7	4.1	4.6	5.0	5.5	6.0	6.6	7.3	7.8	8.2	8.8	9.5	10.0	10.4	11.1	11.6	12.3	12.8	13.3	
Olin 540	NR	NR	3.9	4.3	4.7	5.0	5.6	5.9	6.2	7.0	7.7	8.5	9.2	10.2	11.1	12.1	13.0	14.0	14.9	15.9	16.8	17.8	18.9	19.6	20.7	21.7	22.7	
Olin 571	NR	NR	4.1	4.4	4.9	5.2	5.8	6.1	6.5	7.2	8.0	8.8	9.6	10.7	11.8	12.7	13.7	14.7	15.6	16.8	17.7	18.7	19.7	20.5	21.6	22.8	24.0	
Clays	NR	NR	1.8	2.0	2.2	2.3	2.6	2.7	2.9	3.3	3.6	4.0	4.4	4.8	5.3	5.7	6.1	6.6	7.0	7.5	8.0	8.4	8.9	9.2	9.8	10.3	10.8	
Universal Clays	1.7	2.2	2.5	2.8	3.0	3.1	3.3	3.8	4.0	4.5	5.0	5.5	6.0	6.6	7.3	7.9	8.5	9.1	9.8	10.5	10.9	11.7	12.2	12.7	13.4	14.2	15.0	
International Clays	1.4	1.8	2.2	2.3	2.5	2.7	3.0	3.1	3.3	3.8	4.2	4.7	5.1	5.6	6.1	6.5	7.1	7.7	8.2	8.7	9.2	9.6	10.1	10.6	11.1	11.7	12.4	
453	1.8	2.3	2.7	2.9	3.2	3.4	3.7	3.9	4.2	4.7	5.2	5.7	6.2	6.9	7.5	8.1	8.8	9.5	10.1	10.7	11.3	12.0	12.6	13.2	13.9	14.6	15.3	
Royal 'D'	1.4	1.8	2.2	2.4	2.7	2.8	3.1	3.3	3.5	3.9	4.3	4.8	5.2	5.8	6.4	6.9	7.4	8.0	8.5	8.9	9.4	10.0	10.5	11.1	11.8	12.3	12.9	
Solo 1500	1.5	2.0	2.4	2.6	2.9	3.1	3.4	3.6	3.8	4.3	4.8	5.3	5.8	6.4	7.0	7.5	8.2	8.8	9.3	9.9	10.6	11.1	11.7	12.4	13.1	13.7	14.3	
N 310	1.5	1.9	2.3	2.4	2.7	2.9	3.2	3.3	3.6	4.0	4.5	4.9	5.3	5.9	6.5	7.0	7.5	8.1	8.6	9.2	9.7	10.2	10.8	11.3	11.9	12.6	13.2	
N 320	1.4	1.9	2.2	2.3	2.6	2.8	3.1	3.2	3.5	3.9	4.3	4.8	5.2	5.8	6.3	6.8	7.4	7.9	8.4	9.0	9.5	10.1	10.7	11.1	11.7	12.3	13.0	
N 330	1.6	2.1	2.5	2.7	3.0	3.2	3.5	3.7	4.0	4.4	5.0	5.5	6.0	6.6	7.2	7.8	8.4	9.0	9.8	10.3	11.0	11.6	12.2	12.8	13.5	14.1	14.8	
N 340	1.7	2.2	2.6	2.8	3.1	3.3	3.6	3.8	4.1	4.6	5.1	5.6	6.2	6.7	7.4	8.0	8.6	9.3	9.9	10.6	11.2	11.8	12.4	13.0	13.7	14.4	15.1	
N 350	1.7	2.3	2.7	2.9	3.3	3.5	3.9	4.1	4.3	4.8	5.4	6.0	6.5	7.1	7.8	8.5	9.1	9.8	10.5	11.1	11.8	12.5	13.3	13.9	14.6	15.4	16.1	
WAP	2.3	3.0	3.5	3.8	4.2	4.5	4.9	5.2	5.5	6.2	6.8	7.5	8.2	9.2	10.0	10.8	11.6	12.5	13.2	14.1	15.0	15.8	16.6	17.4	18.3	19.4	20.2	
IMR PB	NR	NR	2.2	2.4	2.6	2.8	3.1	3.2	3.4	3.9	4.3	4.7	5.1	5.6	6.2	6.8	7.2	7.8	8.3	8.8	9.4	10.0	10.5	10.9	11.5	12.0	12.7	
Win Super Lite	NR	NR	3.2	3.5	3.8	4.0	4.4	4.7	4.9	5.6	6.2	6.8	7.4	8.2	9.0	9.7	10.4	11.2	12.0	12.7	13.7	14.4	15.1	15.5	16.5	17.5	18.6	
Win Super Target	NR	NR	2.3	2.5	2.8	3.0	3.3	3.4	3.7	4.1	4.5	5.0	5.4	6.0	6.5	7.1	7.7	8.2	8.8	9.3	10.0	10.9	11.4	12.1	12.6	13.3	14.0	
Win Super Field	NR	NR	3.1	3.4	3.8	4.0	4.4	4.6	4.9	5.5	6.1	6.8	7.3	8.2	9.0	9.7	10.5	11.3	12.1	12.6	13.3	14.2	15.0	15.7	16.4	17.3	18.2	
Power Pistol	2.1	2.7	3.2	3.5	3.8	4.1	4.5	4.7	5.0	5.6	6.2	6.9	7.5	8.3	9.1	9.9	10.6	11.4	12.1	12.9	13.7	14.5	15.2	15.9	16.8	17.7	18.6	
Titte Group	2.0	2.8	3.2	3.5	4.0	4.1	4.4	4.7	5.2	5.9	6.4	7.1	7.7	8.4	9.2	10.1	10.7	11.6	12.5	13.3	14.1	14.5	15.3	16.2	17.2	17.9	18.6	
Lil' Gun	NR	NR	4.1	4.6	5.3	5.4	5.7	6.1	6.6	7.4	8.2	9.2	9.9	10.8	11.8	12.9	13.8	14.9	16.0	17.1	18.0	18.7	19.8	20.8	22.1	22.9	23.6	

NR: No known recommended load

WARNING: The powder charge weights shown for individual rotors are to be used for general reference only. Lot to lot variations in powder density, temperature, humidity, operating techniques and manufacturing tolerances, all introduce variations in charge weights from the values listed. Each rotor-powder combination used MUST be checked on an accurate scale to determine actual charge weight prior to loading ammunition. Read and follow your measure instructions.



PRECISIONEERED® RELOADING EQUIPMENT

We think that we make the very best reloading equipment in the world.

If you agree, please tell your friends. If you disagree, tell us - we want to do something about it!

Customer Service

1-800-533-5000 (US or Canada) or 530-533-5191

Hours: Monday - Thursday, 6:30am - 3:00pm (hours may vary)

e-mail: rcbs.tech@atk.com • www.rcbs.com

RCBS • 605 Oro Dam Blvd. • Oroville, CA 95965

**CCI • SPEER • RCBS
OUTERS • RAMLINE**