

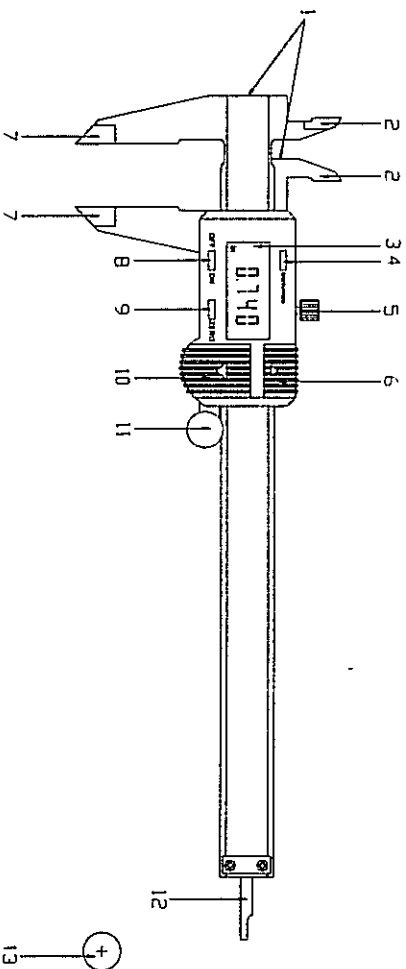

OPERATION INSTRUCTION

Electronic Digital Caliper 0-6"

Measuring range: 0-6"/0-150mm
Accuracy: 0.0012"/0.03mm
Resolution: 0.0005"/0.01mm
Battery: SR44W or SR44



- 1-Step measuring faces
- 2-Internal measuring jaws
- 3-LCD display
- 4-'inch/mm' button
- 5-Locking screw
- 6-RS232 output
- 7-External measuring jaws

- 8-'ON-OFF' button
- 9-'ZERO' button
- 10-Battery cover
- 11-'Thumb wheel
- 12-Depth: measuring bar
- 13-Spare battery(SR44 or SR44W)

1. Clean measuring faces before use.
2. Remove cutting chips, dust, burrs and other foreign substances from the piece to be measured.
3. Buttons
 - 'inch/mm' is for mm and inch conversion.
 - 'ON-OFF' button is to turn on or turn off display.
 - 'ZERO' is to set the reading on display to be zero.

4. Caliper should be checked before each use to make sure that it is properly zero set. The reading should be zero when the external jaws are closed, otherwise press 'ZERO' to set zero reading. Open and close the external jaws to verify if reading returns to zero.
5. Measurement

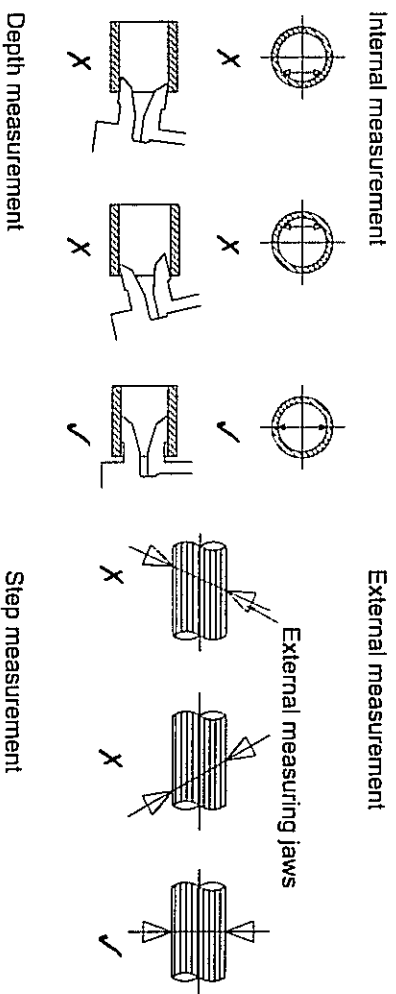

Depth measurement

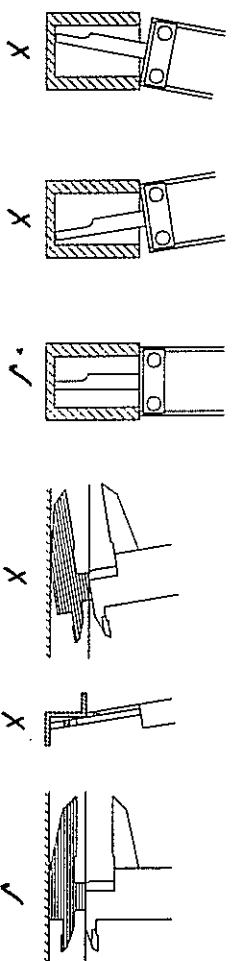

6. One battery will last for one year of continuous use. If there is nothing on display or digits flash, battery voltage is too low, please replace battery (the positive side of battery should face out). If digits do not change when buttons are pressed or vernier is moved, take out battery and put it back after 1 minute. Remove battery if caliper is not to be used for a long period of time.
7. Always apply constant force on thumb wheel during measurement and zero setting.
8. Tighten locking screw to hold reading.
9. Working temperature is 32-72°F. Do not put caliper near strong magnetic field. Keep caliper dry. Prevent liquid from getting into caliper to damage electronics. Do not apply voltage on caliper like engraving with electric pen.
10. Measuring faces should be carefully protected from being scratched or damaged. Do not operate abruptly, drop or strike caliper.